

ASSEMBLY INSTRUCTIONS

SYSTEM 4 BI (Built-In)

Congratulations on your decision to use the world's most advanced and user-friendly cyclorama system. We have taken a great deal of care to create and ship your cyc, so please take a minute to visually inspect the crate before you sign the receipt to accept the shipment. Are there any signs of damage, including puncture holes in the crate, or shattered or stressed wood?

If there is visible damage, insist that the damage be noted on your bill of lading and that either the delivery person or a representative from the delivery company be present when you open the crate. All Pro Cyc crates are custom made for each order. Pro Cyc will not honor claims for damage if the bill of lading has been signed without noting and alerting the carrier of damage to the crate. The only exception is if the damage is internal. In that case, keep the crate so it can be inspected.

Review your Pro Cyc shipment to make sure all items listed on your quote match up to the items shipped. If there is a discrepancy, please call us right away to get the problem resolved.

Let's Assemble Your Cyc:

1. Tools

You will need the following tools & supplies for assembly of the cyc:

- Sockets and drivers; 7/16"
- Sockets & drivers; 1/2" (Expanded corner cyc only)
- Clamps or vise grips
- Chalk line
- Circular saw
- 24" long level
- Carpenter's square
- 1/8" drill bit
- Drift pin to align 9/32" holes

- 9/32" drill bit (Expanded corner cyc only)
- Drill motor
- Roto-hammer with 5/32" masonry drill bits (only if attaching cyc to concrete floor)
- Canned air
- Dry mortar mix (One 80-pound bag for every 12 linear feet of cyc floor length)
- Framing hammer
- Screwdriver (Phillips & flat)
- Palm sander w/60-grit sandpaper
- Clean shop towels or cloths
- Sheetrock knife
- Drywall tools
- Pro Cyc's Grey Bonding Primer
- Paint
- Paint supplies
- ABS plastic glue or cement (Available in plumbing supply stores. This adhesive is only required if you need to trim your cyc to fit your studio.)

2. Sanding the Modules

Sand the entire surface of each cyc module with 60-grit sandpaper. This will provide for better paint adhesion.

Sand the outside edges and the side flanges with 60-grit sand paper. This will provide for better joint compound adhesion and help create a non-slip surface when bolting the modules together.

Sanding before assembly will help make sure outside edges coming in contact with the joint compound are not missed.

After sanding, clean each module with a damp cloth. Dust from the sanding process can interfere with paint and joint compound

adhesion. This is also a good time to clean the sanding dust from your studio.

3. Framing

The first step in construction is framing. It is very important that the wall you are going to integrate with your Pro Cyc is as straight as possible – whether it is an existing wall that is built out (Figures A-C), or a new wall (Figures D-F). Since each of the modules will be attached to the framing, the straightness of the wall will determine how well the modules butt together. Also, take care when placing the walls.

If you are installing a corner module, be sure to understand how far the walls are to be apart from one another. This applies when two corner modules are joined together and also when two corners are assembled with one or more flat modules in between the corner modules (expanded corner). Begin in the corner. **If your cyc has two corner modules joined together**, refer to Figure B and measure from the corner 5 ft. 4 1/4 in., plus the thickness of your built-out wall, including sheetrock (Note A). **If your expanded corner cyc has a single straight 4B module between two corner modules**, use Figure B.1 and measure 8 ft. 2 1/4 in., plus the thickness of your built-out wall, including sheetrock. **If your expanded corner cyc has two straight 4B modules between the two corners**, use Figure B.2 and measure out 11 ft. 1/4 in., plus the thickness of the built-out wall, including sheetrock.

4. Installing the Corner

(If you are not using any corner modules, disregard this and proceed to the next section.)

For non-expanded corners, use a 1/4"-20 x 1" bolt, a nut and two washers in each hole to attach two 4B45 modules together side by

side. Make sure these modules are flush by using a straight edge on the front side. Using 1-1/4" Phillips drywall screws every 4 in., attach this pair of modules to your built-out wall from the back. (Use self-tapping sheet-metal screws if you are using metal studs.) Make sure the face of these modules end up flush with the sheetrock (Figure J). The bottom of the 4B45 modules should be 3 ft. 11 3/4 in. above the floor (Figures C or F). Attach all 4B45 modules on top of this first row in the same manner. Next, attach the two corner modules together using a 1/4"-20 x 1" bolt, a nut and two washers in each hole. Again, make sure the surfaces are flush before tightening the nuts and bolts. When these two modules are firmly attached together, slide the unit up under the vertical cove. Have an assistant make sure the faces are flush, then bolt the corner group to the vertical coves using a 1/4"-20 x 1" bolt, a nut and two washers in each hole. **Do not attach the corner to the floor until the entire cove system is assembled.**

When installing System 4 BI with an expanded corner, you will need to build the corner assembly using leg assemblies, Part #4B and Part #4C. See the instructions for System 4 FS and review the schematics for System 4 BI with an Expanded Corner. Both of these documents can be found at our website www.procy.com. Bolt the 4A45 corner modules and 4B45 modules to the expanded corner before moving this entire assembly into position.

5. Installing the Straight 4B Modules

Installing 4Bs can be done one at a time or as a group. To install these straight coves your straight wall must be in place and finished with sheetrock according to Figures C or F. The bottom edge

of the wall or sill plate should be 3 ft. 11 3/4 in. off the floor.

Use a 1/4"-20 x 1" bolt, a nut and two washers in each hole to connect adjacent modules (Figures G and H).

With the help of an assistant, bring the modules up to the built-out wall. Hold the coves in place so that the faces of the modules are flush with the surface of the sheetrock wall (Figure J).

When installing a system with a corner, begin at the corner and bolt the 4B module to the corner module.

Make sure the faces of all adjacent modules are flush with each other before tightening. Attach the cove modules to the wall by screwing through the flange into the bottom plate of the built-out wall every 4 in. using 1-1/4" Phillips drywall screws. (Use self-tapping sheet-metal screws if you are using metal studs.) Again, make certain that the faces of the modules are flush with the face of the sheetrock wall. Continue until all of the modules are fastened into the wall.

6. Trimming Your Cyc to Fit Your Studio – Part #4B (See Figure L)

Snap a chalk line at the desired length and use a circular saw to cut the module to the size.

Next, cut the remaining part one inch from the flanged end so you can re-attach the flange. Clean off any burrs or debris from the plastic before using ABS adhesive or cement (available in plumbing supply stores) to fasten the flanged end behind (under) the cut-to-length module. Clamp the parts together until the glue is dry.

You will need to trim the floor side of the flange back to the point where it will allow you to align the

face of the trimmed module with the face of the adjoining module.

7. Trimming Your Cyc to Fit Your Studio – Part #4B45

Snap a chalk line at the desired length and use a circular saw to cut the module to the size. It is not necessary to reattach the flange to the top of this part. The cut edge will become the top of the cyc.

8. Fastening the Bottom Edge to the Floor

To secure the cyc to the floor, begin in the corner and work toward each end of the cyc. Using both hands, grab the cyc from underneath, pull it forward, and then let it fall gently into place.

Drill through the cove modules into the floor. If you are attaching to concrete, you should use a roto-hammer and 5/32" carbide masonry drill bits to install 3/16" x 1-1/4" flat-head Phillips concrete screws. Drill the holes a minimum of 1-1/2" deep. If you are fastening into a wood floor, you should use 1/8" drill bits to install 1-1/4" Phillips drywall screws.

Before installing the screws blow out each hole with canned or compressed air.

9. Finish the Joints and the Tapered Edge at the Floor

The tapered edge at the floor may be done either simultaneously with the joint mudding or subsequent to the joints. The completed feathered edge at the cyc-to-studio-floor transition will typically extend 4" to 6" in front of the front edge of the cyc modules. This feathered edge completes the radius of the cove module.

The process for finishing the joints and the tapered edge at the floor is the same:

Make sure that the surfaces of all modules are properly sanded (see

Step 2.) and wiped down in order to remove sanding dust. Use a self-adhesive fiberglass mesh tape on the joints. Be sure to press the tape into the crack with your finger as you apply the tape. Use a 90-minute drywall mud such as Durabond 90 Setting Type Joint Compound to mud the joints.

DO NOT USE EASY SAND JOINT COMPOUNDS, AS THEY HAVE POOR TACKING QUALITIES.

ALLOW PLENTY OF TIME FOR THE MUD TO COMPLETELY DRY BEFORE APPLYING SUBSEQUENT COATS. This is because moisture can only escape through the face of the joint. Wet sand or dry sand the joints and re-coat with the 90-minute mud. Wet or dry sand again. For the third and final coat, use a regular box or bucket mud, such as Beadex All Purpose Joint compound, to float out the seams. Sand and wipe down the cyc one last time before painting.

Do not cap off the ends or the top of the corner on your cyc. It is important to allow the free flow of air behind the cyc.

Temperature differences between the front and the back of the cyc can create uneven expansion and contraction. This can cause drywall mud to crack.

10. Reinforce the Tapered Edge at the Floor

It provides additional support to the cyc to put dry mortar mix underneath the area where the cyc meets the floor. Do this to a height of approximately 1-1/2" as depicted in the drawing below. Use a spray bottle to spray water on the back side of the mortar mix and allow mortar to set.

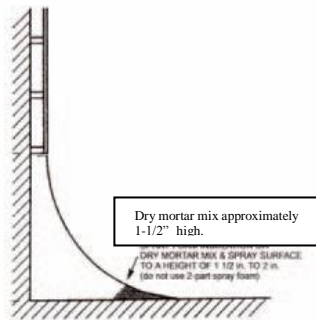

11. Prime & Paint the Cyclorama

Wipe the entire cyc with a clean damp cloth – including the sheetrock wall. It is now ready to be primed. Apply one generous

coat of Pro Cyc's Grey Bonding Primer using a 9" roller with a 3/8" nap. Use a 3" or 4" roller in the corner area.

Paint your cyc with either a roller or an airless spray gun. See Pro Cyc's Helpful Construction Hints (available for download on our website) for useful tips on painting your cyc with a roller.

Repaint as often as necessary over the life of the cyc. Clean between each coat. Wearing surgical booties and/or putting plastic on the floor covers during rehearsal or studio prep will prolong the time between new coats of paint.

12. Questions?

Please give us a call at: (503) 723-7448. You can also email us at:

info@procyc.com

Instructions, videos, schematics, helpful construction hints and other recommendations can be found on our website:

www.procyc.com

FIGURE A - Perspective
EXISTING WALL

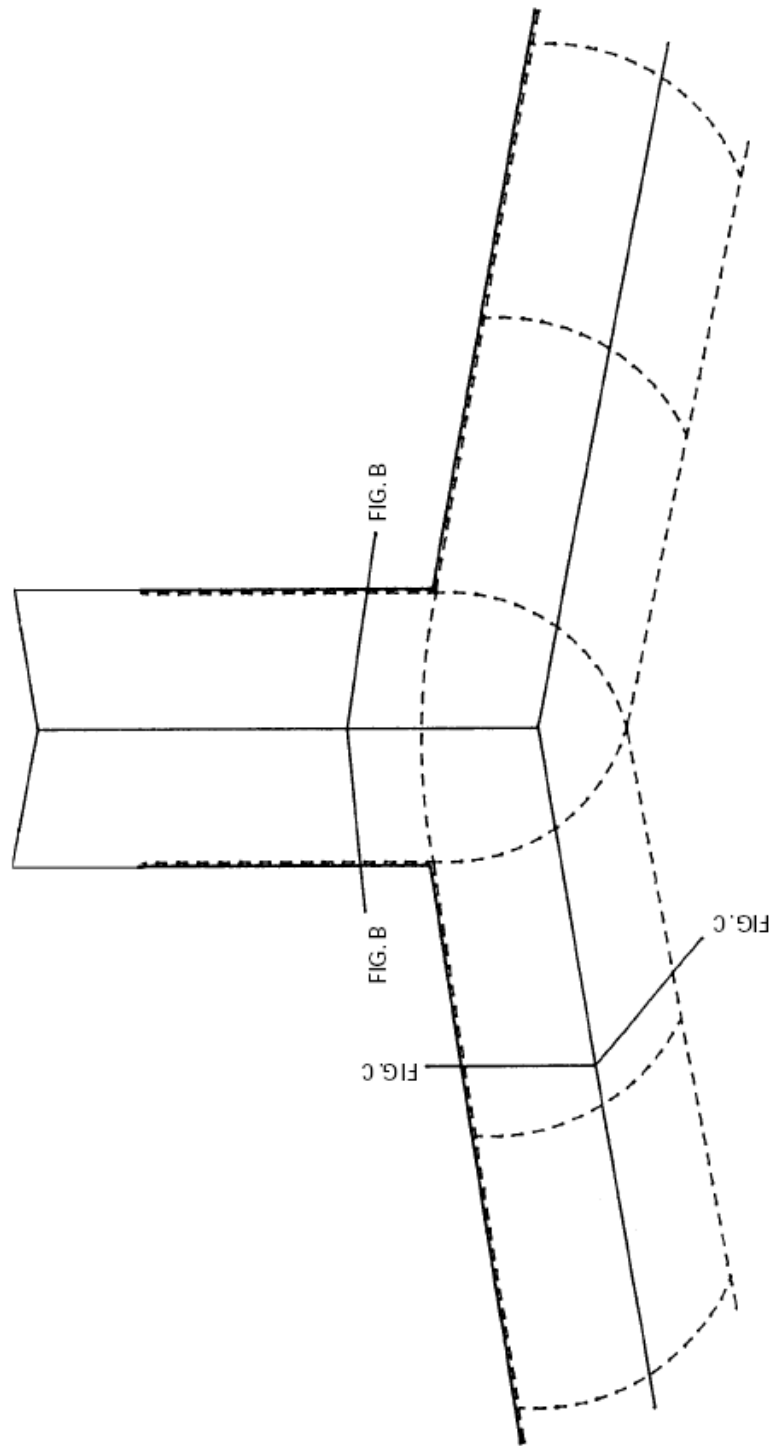

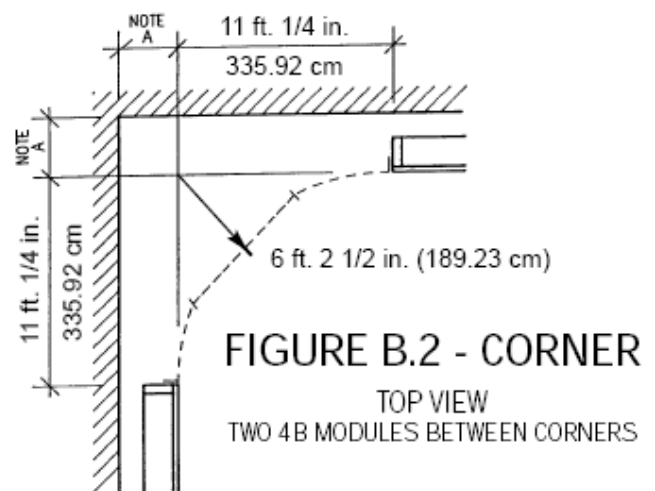
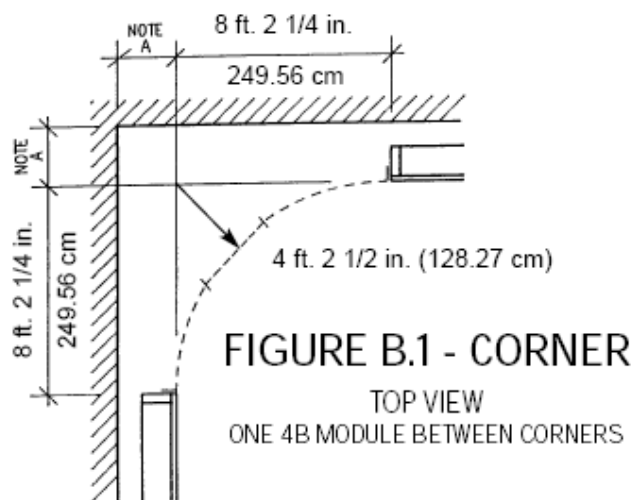
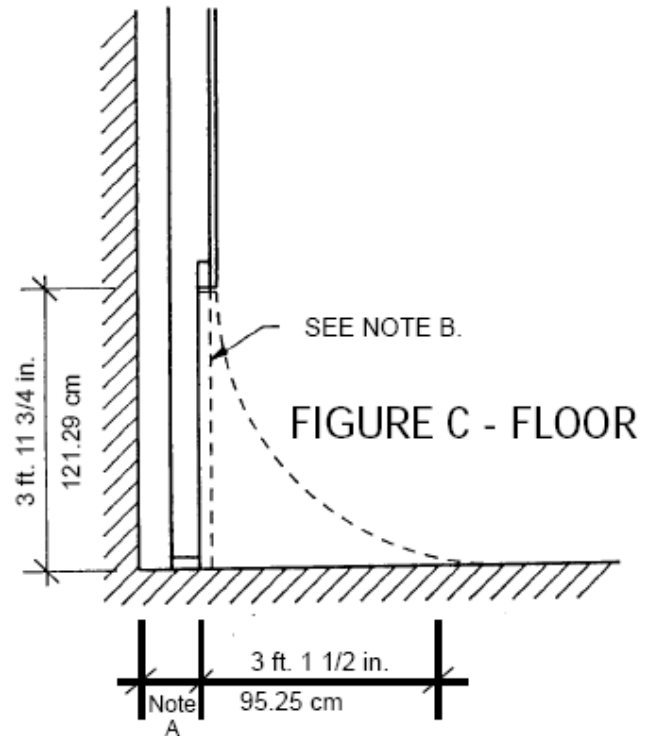
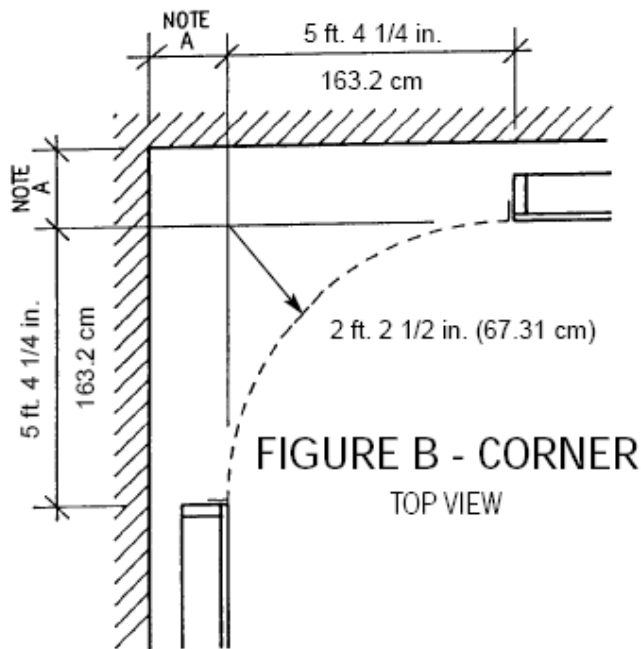

NOTE A. ADD DISTANCE FROM FACE OF EXISTING WALL TO FACE OF NEW WALL TO 5 ft. 4 1/4 in. TO FIND THE DISTANCE FROM CORNER OF SIDE OF NEW WALL.

NOTE B. NOTCH WALL TO CREATE OFFSET FOR COVE MODULES. OFFSET MUST BE A MIN. OF 3 in. (7.62 cm) FACE OF NOTCH TO FACE OF FINISH. RECOMMEND WALL CONSTRUCTION BE A MINIMUM OF 2 in. X 6 in. (5.08 cm x 20.3 cm) WOOD STUDS AT 24 in. (60.96 cm) ON CENTER NOTCHED AT 3 ft. 11 3/4 in. ABOVE THE FLOOR OR 3 5/8 in. (9.2 cm)-20 GA. METAL STUDS VERTICALLY AT 24 in. (60.96 cm) ON CENTER WITH 2 1/2 in. (6.35 cm) - 20 GA. METAL STUDS HORIZONTALLY AT 24 in. (60.96 cm) - ON CENTER, STARTING AT 3 ft. 11 3/4 in. ABOVE THE FLOOR. FINISH WITH 5/8 in. (1.6 cm) - SHEETROCK.

FIGURE D - Perspective
NEW WALL

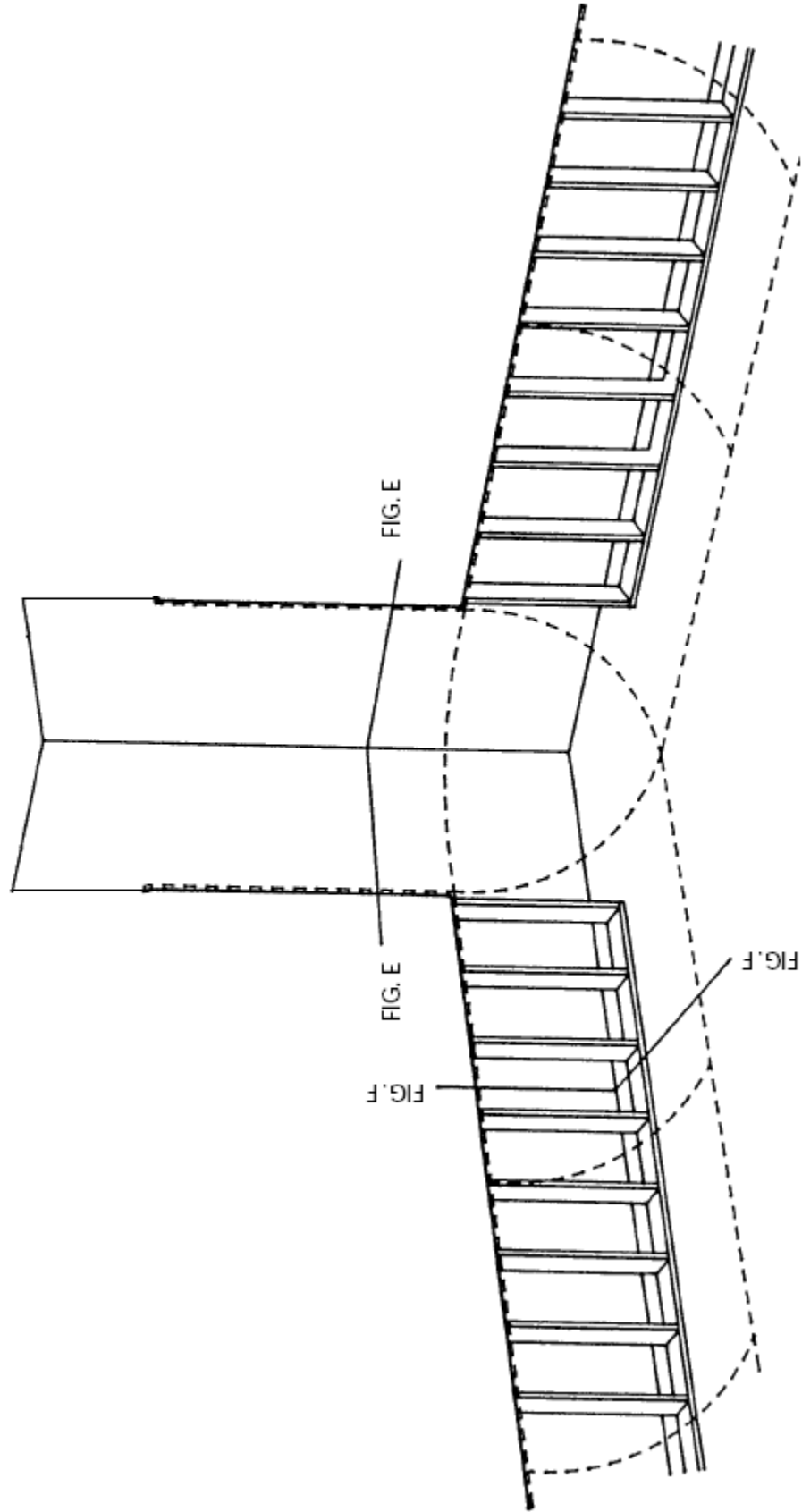

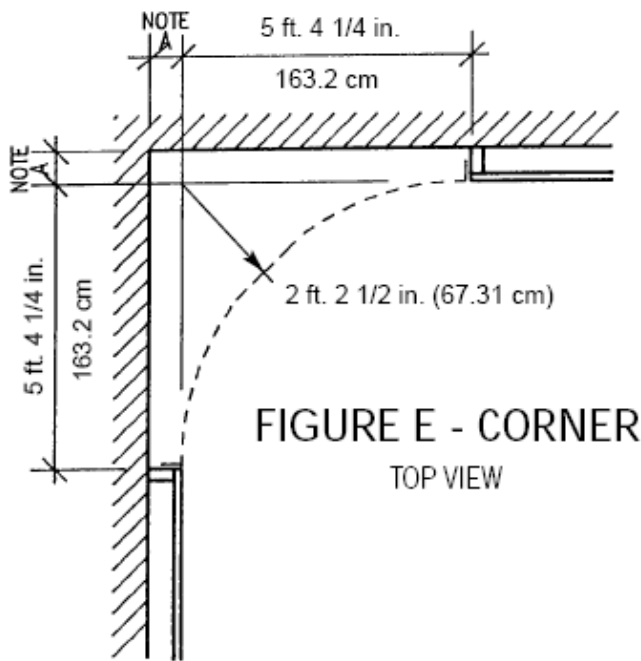

FIGURE E - CORNER
TOP VIEW

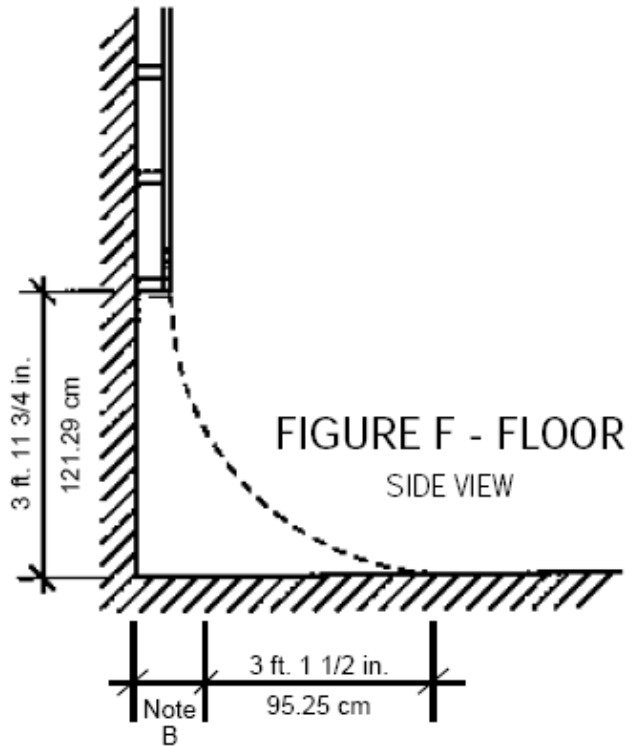

FIGURE F - FLOOR
SIDE VIEW

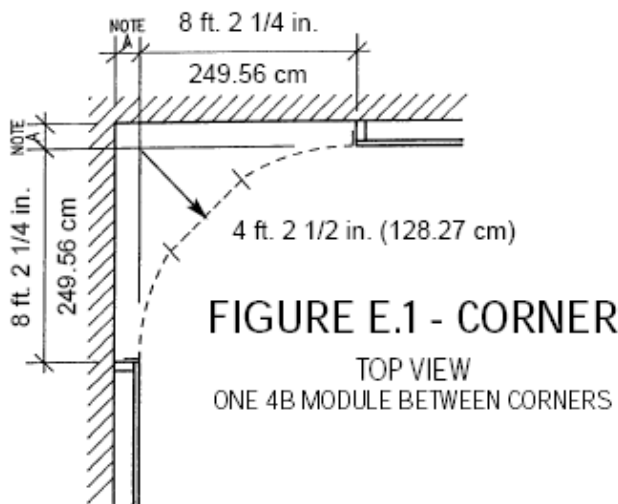

FIGURE E.1 - CORNER
TOP VIEW
ONE 4B MODULE BETWEEN CORNERS

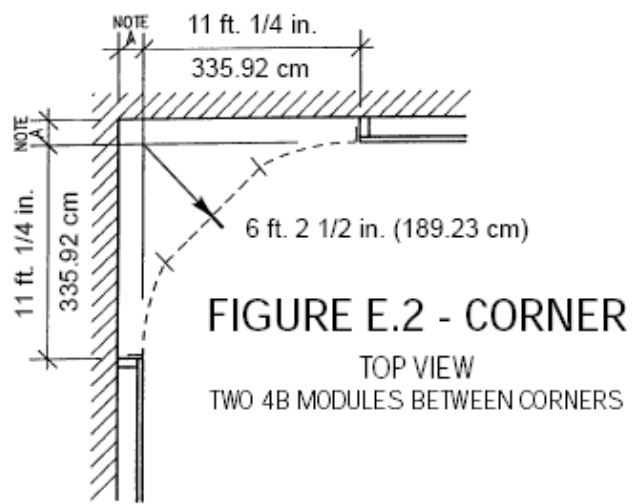
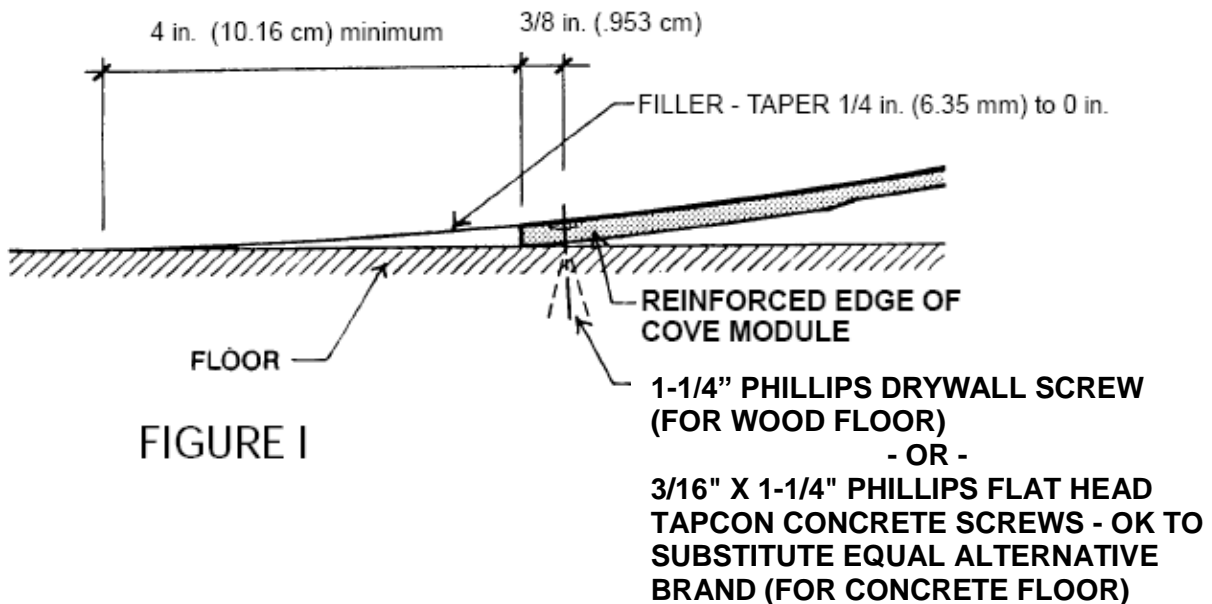
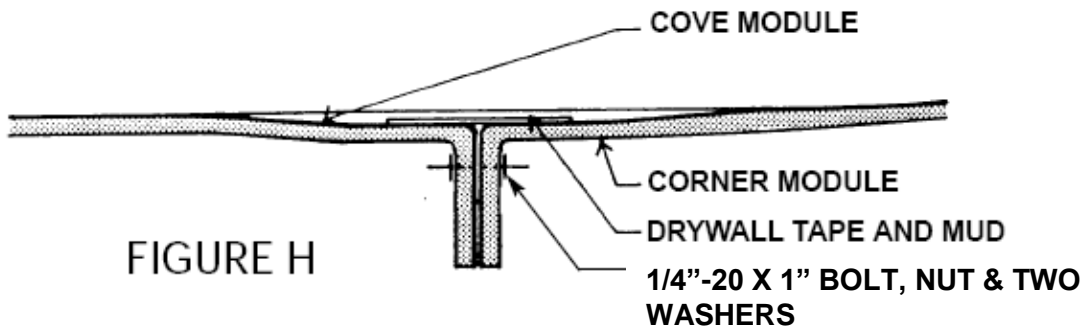
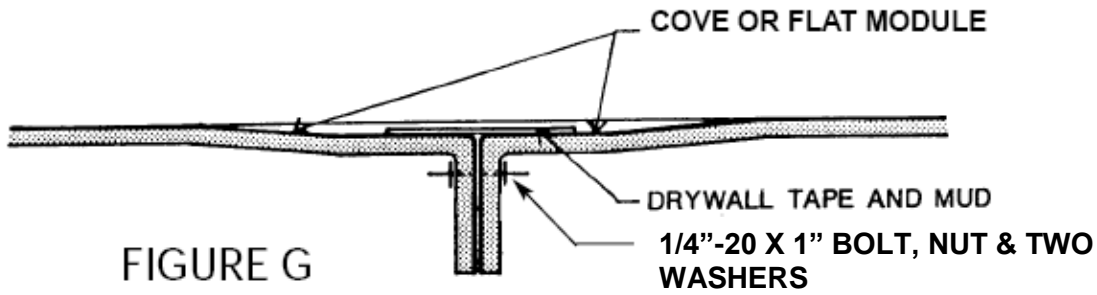

FIGURE E.2 - CORNER
TOP VIEW
TWO 4B MODULES BETWEEN CORNERS

NOTE A. ADD THICKNESS OF FURRED OUT WALL TO 5 ft. 4 1/4 in. TO FIND THE DISTANCE FROM CORNER TO SIDE OF FURRED OUT WALL. RECOMMEND FURRED OUT WALL BE 2 in. X 4 in. (5.08 cm x 10.1 cm) WOOD STUDS OR 3 5/8 in. (9.2 cm) - 20 GA. METAL STUDS ATTACHED TO THE EXISTING WALL HORIZONTALLY AT 2 ft. (60.96 cm) ON CENTER WITH 5/8 in. (1.6 cm) SHEETROCK FINISH.

NOTE B. ADD THICKNESS OF FURRED OUT WALL TO 3 ft. 1 1/2 in. TO FIND DISTANCE FROM EXISTING WALL TO FLOOR.



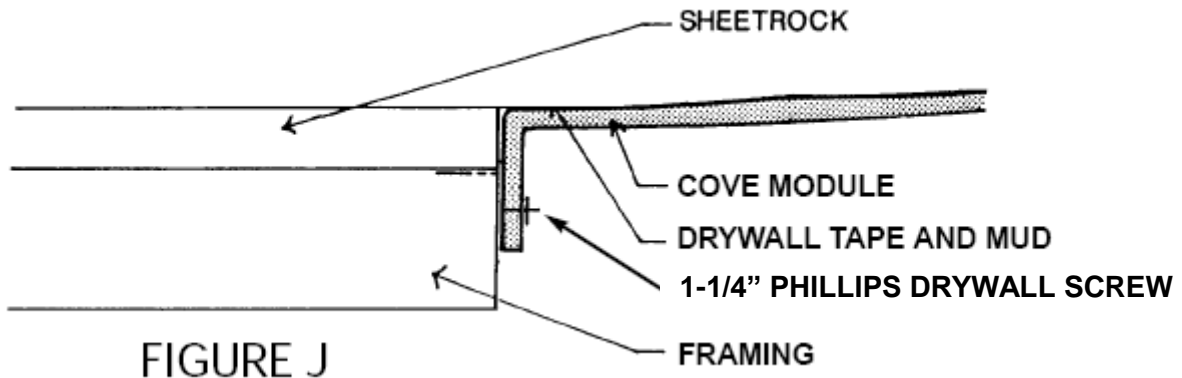

Figure L

